

Pilot's Operating Handbook & approved Flight Manual FK 9 Mk VI



POH FK 9 Mk VI
Advanced Italien regulation
type

Approved as Light Sport Aircraft / Ultralight

DPR 133/Annex V°

Airplane Serial Number: _____

Airplane Registration Number: _____

Date of issue: _____

Manual Nr.:

9-Mk VI- _____ - _____

**Manufacturer, Design Organisation and
Owner of IP Rights:
B & F Technik Vertriebs GmbH Speyer – Germany**

document code: des.002

0. Introduction

0.1. Revisions

The owner/operator is responsible for keeping all pages of this manual to the revision status indicated in the table, by exchanging the relevant pages as and when a new revision is published.

For updates check www.FK-servicecenter.com or www.flugservice-speyer.de regularly.

Revisions and Service Bulletins for the ROTAX engine are available on www.rotax-aircraft-engines.com .

This revision information page shall be filed behind the checklist for amendments for about 6 month in order to get at a glance all the changes

Index/Page	remove REV	insert REV	Remark / Reason for REV
several		REV 1	certification requirements
several		REV 2	certification requirements
several		REV 3	minor changes
several		REV 4	minor changes

0.2. Record of Revisions

The fact of having inserted revised pages shall be confirmed in the list below.

Revision		inserted
No.	of	by --- on
1	01.12.20	author
2	01.02.21	author
3	02.02.22	author
4	01.05.22	author

Revision		inserted
No.	of	by --- on

List of effective Pages

Page	Revision	Date		Page	Revision	Date
0-1	4	1.5.22		0-2	4	1.5.22
0-3	4	1.5.22		0-4	1	1.12.20
0-5	1	1.12.20		0-6	1	1.12.20
0-7	1	1.12.20		0-8	1	1.12.20
0-9	1	1.12.20		0-10	FE	1.07.20
0-11	FE	1.07.20				
1-1	1	1.12.20		1-2	4	1.5.22
1-3	3	2.2.22		1-4	FE	1.07.20
2-1	3	2.2.22		2-2	3	2.2.22
2-3	4	1.5.22		2-4	3	2.2.22
2-5	3	2.2.22		2-6	2	01.02.21
2-7	4	1.5.22				
3-1	4	1.5.22		3-2	4	1.5.22
3-3	2	01.02.21		3-4	FE	1.07.20
4-1	3	2.2.22		4-2	3	2.2.22
4-3	3	2.2.22		4-4	FE	1.07.20
4-5	3	2.2.22		4-6	3	2.2.22
4-7	3	2.2.22		4-8	4	1.5.22
4-9	4	1.5.22				
5-1	3	2.2.22		5-2	3	2.2.22
5-3	3	2.2.22				
6-1	FE	1.07.20		6-2	3	2.2.22
6-3	3	2.2.22				
7-1	3	2.2.22		7-2	3	2.2.22
7-3	3	2.2.22		7-4	3	2.2.22
7-5	3	2.2.22		7-6	3	2.2.22
7-7	3	2.2.22		7-8	3	2.2.22
7-9	4	1.5.22		7-10	3	2.2.22
7-11	3	2.2.22		7-12	4	1.5.22
7-13	4	1.5.22		7-14	4	1.5.22
7-15	3	2.2.22		7-16	3	2.2.22
8-1	FE	1.07.20		8-2	3	2.2.22
8-3	FE	1.07.20		8-4	1	1.12.20
8-5	2	01.02.21		8-6	2	01.02.21
8-7	FE	1.07.20		8-8	FE	1.07.20
9-1	FE	1.07.20		9-2	2	01.02.21

0.3. Table of Contents

0. INTRODUCTION.....	0-1
0.1. Revisions.....	0-1
0.2. Record of Revisions.....	0-2
0.3. Table of Contents	0-4
0.4. Introduction.....	0-10
1. GENERAL.....	1-1
1.1. Airplane Three Side View.....	1-1
1.2. Technical Data	1-2
1.3. Weight.....	1-2
1.4. Airspeeds and Performance.....	1-2
1.5. Fuel	1-3
1.6. Engine.....	1-3
1.7. Abbreviations and Terminology.....	1-3
2. LIMITATIONS	2-1
2.1. General	2-1
2.2. Airspeed Limitations	2-1
2.3. Airspeed Indicator Markings	2-2
2.4. Power Plant Limitations.....	2-2
2.5. Propeller	2-3

2.6.	Service Ceiling.....	2-3
2.7.	Weights.....	2-4
2.8.	C.G. Limits.....	2-4
2.9.	Maneuvers.....	2-4
2.10.	Flight Load Factors	2-5
2.11.	Kind of Operation	2-5
2.12.	Fuel	2-5
2.13.	Passenger Seating	2-5
2.14.	Colour.....	2-6
2.15.	Electric.....	2-6
2.16.	Power Plant Instrument Marking.....	2-6
2.17.	Placards.....	2-7
3.	EMERGENCY PROCEDURES.....	3-1
3.1.	General	3-1
3.2.	Airspeeds for Emergency Procedures	3-1
3.3.	Engine / Carburetor Fire	3-1
3.4.	Engine Failure.....	3-1
3.5.	Emergency Landing	3-2
3.6.	Emergency Descent	3-2
3.7.	Strong Vibrations	3-3
3.8.	Steering Problems.....	3-3

3.9.	Flap Failure	3-3
3.10.	Oil Pressure Low	3-3
3.11.	Fuel Pressure Low.....	3-3
3.12.	Generator Fault.....	3-3
3.13.	Fire and Smoke (Electric)	3-4
3.14.	Stall recovery	3-4
4.	NORMAL PROCEDURES	4-1
4.1.	General	4-1
4.2.	Recommended Speeds	4-1
4.3.	Regular Inspection	4-1
4.4.	Preflight Inspection	4-1
4.5.	Engine Start	4-5
4.6.	Taxi	4-5
4.7.	Before Take-off	4-6
4.8.	Takeoff.....	4-6
4.9.	Climb.....	4-7
4.10.	Cruise	4-7
4.11.	Descent.....	4-7
4.12.	Landing.....	4-8
4.13.	Balked Landing.....	4-9
4.14.	Touch and Go	4-9

4.15.	After Landing / Parking	4-9
5.	PERFORMANCE	5-1
5.1.	General	5-1
5.2.	Takeoff Distance	5-1
5.3.	Climb Performance.....	5-2
5.4.	Cruise Performance	5-2
5.5.	Landing Distance.....	5-3
6.	WEIGHT AND BALANCE.....	6-1
6.1.	General	6-1
6.2.	Basic Empty Weight	6-1
6.3.	Determination of C.G. for the Flight.....	6-3
7.	SYSTEMS DESCRIPTION.....	7-1
7.1.	General	7-1
7.2.	Instrument Panel	7-1
7.3.	MID (Multi Information Panel).....	7-3
7.4.	Rescue system	7-6
7.5.	Flaps	7-7
7.6.	Tyres	7-7
7.7.	Baggage	7-7
7.8.	Seats and seatbelts	7-7

7.9.	Doors	7-8
7.10.	Engine	7-8
7.11.	Propeller	7-8
7.12.	Fuel System	7-8
7.13.	Brakes	7-14
7.14.	Heating and Ventilation	7-14
7.15.	Electrical System	7-14
8.	HANDLING, SERVICING AND MAINTENANCE	8-1
8.1.	General	8-1
8.2.	Ground Handling	8-1
8.3.	Cleaning	8-1
8.4.	General Advice	8-1
8.5.	Regular Maintenance / Lubrication Schedule	8-2
8.6.	Time between Overhaul (TBO)	8-2
8.7.	Airplane Servicing	8-4
8.8.	Control Surface Angle	8-4
8.9.	Jacking / Towing / Storage	8-5
8.10.	Main / Subsidiary Structure	8-6
8.11.	Materials for minor repairs	8-6
8.12.	Special Repair and Check Procedures	8-6
8.13.	Required Tools	8-6

8.14.	Weighing	8-6
8.15.	Mounting / Maintenance of the Rescue System	8-7
8.16.	Assembly of the Aircraft	8-7
9.	SUPPLEMENTS	9-1
9.1.	General	9-1
9.2.	Engine Manual	9-1
9.3.	Rescue System	9-1
9.4.	Avionics / Special Engine Instruments	9-1
9.5.	Seaplane Floats	9-1
9.6.	Sailplane Towing	9-2
9.7.	Airplane Flight Training Supplement.....	9-2

0.4. Introduction

This is the Pilot's Operating Handbook and approved flight manual. It contains information required to be furnished to the pilot and must be carried in the aircraft at all times.

This manual must be read carefully by the owner and operator in order to become familiar with the operation of the FK 9. The manual presents suggestions and recommendations to help obtain safe and maximum performance without sacrificing economy.

The owner and operator should also be familiar with the applicable aviation regulations concerning operation and maintenance of this airplane.

All limits, procedures, safety practices, servicing, and maintenance requirements contained in this manual are considered mandatory for the continued airworthiness of the airplane.

All values in this manual are based on ICAO Standard Atmosphere conditions and maximum takeoff weight (MTOW) unless otherwise indicated.

The pilot in command has to make sure that the airplane is airworthy and operated according to this manual.

Non-compliance with handling, maintenance and checking instructions as indicated in the flight and maintenance manuals will void warranty and/or guarantee claims.

All variants of airframes and powerplants can be combined as certified.

0.4.1. Certification Basis

This airplane meets following ASTM standards:

- F 2245-10c Design and Performance of a Light Sport Airplane
- F 2483-05 Maintenance and the Development of Maintenance Manuals for Light Sport Aircraft
- F 2746-09 Standard Specification for Pilot's Operating Handbook for Light Sport Airplane
- LTF UL 2019

0.4.2. Design Organization, Owner of IP Rights and Customer Support

B&F Technik Vertiebs GmbH Speyer – Germany
Anton-Dengler-Str. 8
D-67346 Speyer
Tel.: +49 (0) 6232 – 72076
Fax: +49 (0) 6232 – 72078
email: info@fk-aircraft.com
Service & parts only via service@fk-aircraft.com
Homepage: www.fk-aircraft.com

This Pilot's Operating Handbook is issued by B&F Technik Vertriebs GmbH and no part of this manual may be reproduced or changed in any manner without written consent.

1. General

The FK 9 is a high-wing airplane with two side by side seats and nose- or tailwheel landing gear.

1.1. Airplane Three Side View

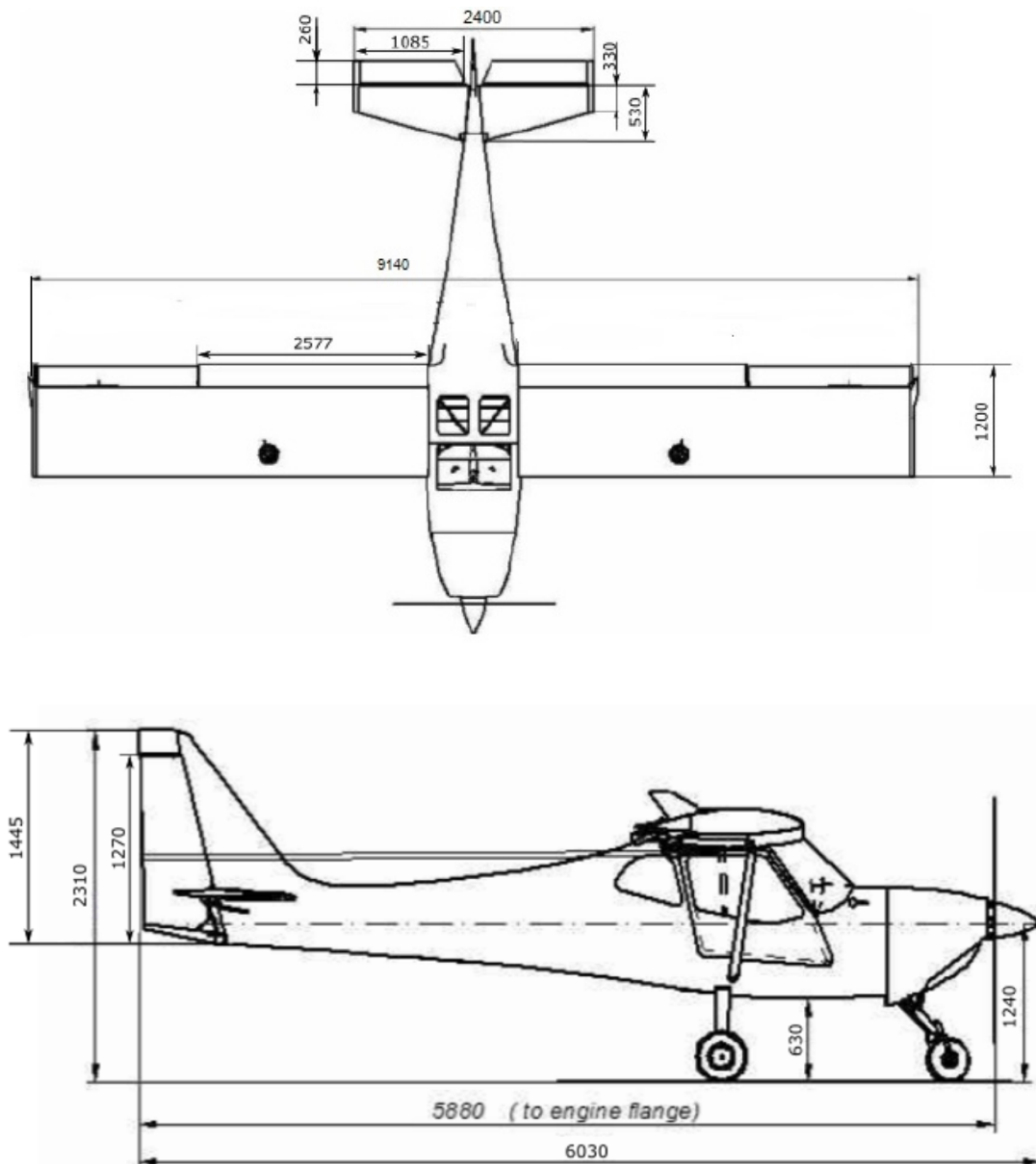

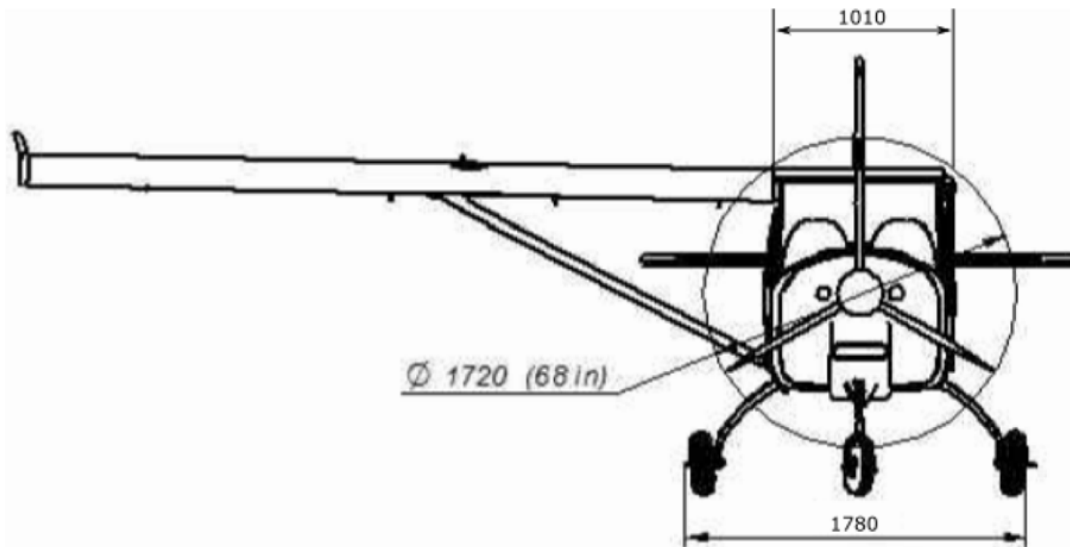

1.2. Technical Data

Wing span: 9,14m / 29,99 ft
Wing area: 10,97m / 118,08 sqft

Length: 6,03m / 19,78 ft
Height: 2,31m / 7,58 ft

1.3. Weight

The aircraft has a maximum take-off weight depending on configuration and certification (respective country rules) of up to 640 kg (1410 lbs).

1.4. Airspeeds and Performance

all speeds CAS, ISA conditions, ROTAX 912S

	grossweight:	472,5 kg	525 kg	600 kg
Top speed (0ft ISA, MTP)		205 km/h 110 kt	205 km/h 110 kt	205 km/h 110 kt
Cruise speed (2000ft ISA, 75% MCP)		195 km/h 105 kt	190 km/h 103 kt	190 km/h 103 kt
Maximum range (2000ft ISA, 75% MCP) (wing tank 110 Ltr / 10 Ltr. Res.)		1000 km 540 NM	975 km 526 NM	975 km 526 NM
Best rate of climb Vy (flaps up)		110 km/h 59 kt	118 km/h 64 kt	136 km/h 73 kt
Best angle of climb Vx (flaps 1)		100 km/h 54 kt	100 km/h 54 kt	102 km/h 55 kt
Stall speed flaps up		78 km/h 42 kt	83 km/h 45 kt	89 km/h 48 kt
Stall speed flaps full down		64 km/h 35 kt	69 km/h 37 kt	74 km/h 40 kt

1.5. Fuel

Capacity	total fuel capacity	total useable fuel
fuselage tank version	60 Ltr (15,8 USG)	57 Ltr (15 USG)
add. optional wing tanks	40 Ltr (10,5 USG)	36 Ltr (9,5 USG)
wing tank version	110 Ltr (29 USG)	105 Ltr (27,7 USG)

Approved Fuel Grades:

UL 91 recommended, MOGAS (with regard to TM-FK001-2011), AVGAS 100LL.

AVGAS should only be used if no other fuel is available or in case of problems caused by vapour locks (check engine manual).

1.6. Engine

engine	max.T/O PWR (5 minutes)	max. continuous PWR
ROTAX 912 S	73,5 kW (100hp) at 5800 RPM	69 kW (93hp) at 5500
ROTAX 912	59,6 kW (81hp) at 5800 RPM	58 kW (78hp) at 5500

1.7. Abbreviations and Terminology

a) Speeds

IAS	Indicated airspeed = speed as shown on the airspeed indicator
CAS	Calibrated Airspeed is the indicated airspeed, corrected for position and instrument error. CAS is equal to TAS in standard atmosphere at sea level
TAS	True airspeed = speed relative to undisturbed air
VA	Maneuvering speed = max. speed at which application of full available aerodynamic control will not overstress the airplane
VRA	Maximum speed in turbulence
VFE	Maximum speed with flaps extended
VNE	Never exceed speed is the speed limit that must not be exceeded at any time
VNO	Maximum structural cruising speed is the speed that should not be exceeded except in smooth air and only with caution
VS	Stalling speed or the minimum steady flight speed at which the airplane is controllable
VSO	Stalling speed in landing configuration (full flaps)
VX	Best angle of climb speed which delivers the greatest gain of altitude in the shortest possible horizontal distance
VY	Best rate of climb speed which delivers the greatest gain of altitude in the shortest possible time

b) Meteorological

ISA	International Standard Atmosphere: OAT in MSL 15°C; pressure in MSL 1013,2hPa; air a perfect dry gas; temperature gradient of 0,65°C per 100m
MSL	Mean sea level
OAT	Outside air temperature

c) Weight and Balance

Reference Datum	An imaginary vertical plane from which all horizontal distances are measured for balance purposes
Arm	The horizontal distance from the reference datum to the center of gravity of an item
Moment	The product of the weight of an item multiplied by its arm
Airplane center of gravity (C.G.)	The point at which an airplane would balance if suspended. Its distance from the reference datum is found by dividing the total moment by the total weight of the airplane
C.G. arm	The arm obtained by adding the airplane's individual moments and dividing the sum by the total weight
C.G. limits	The extreme center of gravity locations within which the airplane must be operated at a given weight
Empty weight	Weight of the airplane including unuseable fuel, full operating fluids and full oil; equipment as indicated

d) Conversions

1 Liter (Ltr)	=	0,264 USG	1 USG	=	3,785 Ltr
1 m	=	3,28 ft	1 ft	=	0,3048 m
1 km/h	=	0,54 kt	1 kt	=	1,852 km/h
1 cm	=	0,394 inch	1 inch	=	2,54 cm
1 bar	=	14,5 psi	1 psi	=	0,069 bar
1 kg	=	2,2 lbs	1 lbs	=	0,45 kg

2. Limitations

2.1. General

This chapter contains limitations, instrument markings and placards required for the safe operation of the aircraft.

Limitations valid for additional equipment can be found in chapter 9 (supplements).

2.2. Airspeed Limitations

	472,5kg / 1042 lbs	525kg / 1157 lbs	600kg / 1323 lbs
V_{NE}^*	230 km/h / 124 kt	230km/h / 124 kt	230km/h / 124 kt
V_{NO}	184 km/h / 99 kt	184 km/h / 99 kt	184 km/h / 99 kt
V_A	159 km/h / 86 kt	167 km/h / 90 kt	179 km/h / 97 kt
(Flaps 1) V_X	100 km/h / 54 kt	100 km/h / 54 kt	102 km/h / 55 kt
(Flaps up) V_Y	110 km/h / 59 kt	118 km/h / 64 kt	136 km/h / 73 kt
CWC	27 km/h / 15 kt		
V_{FE}	130 km / 70 kt	130 km/h / 70 kt	130 km/h / 70 kt
$V_{S\text{ clean}}$	78 km/h / 42 kt	83 km/ h / 45 kt	89 km/h / 48 kt
V_{S0}	64 km/h / 35 kt	69 km/h / 37 kt	74 km/h / 40 kt

*** Caution:**

During flights above 7500ft (pressure altitude) the V_{NE} is reduced to 205km/h / 110kt.

This assures that - despite of the high TAS – there is enough margin to the tested flutter speeds.

2.3. Airspeed Indicator Markings

The airspeed indicator has following markings and shows IAS in [km/h / kt]:

	472,5kg / 1042 lbs	525kg / 1157 lbs	600kg / 1323 lbs
white arc: 1,1*VSO to VFE full flap operating range	71 - 130 km/h 38 to 70 kt	76 - 130 km/h 42 to 70 kt	82 - 130 km/h 43 to 70 kt
green arc: 1,1*VS1 to VNO normal operating range (flaps up)	86 - 184 km/h 46 to 99 kt	91 - 184 km/h 49 to 99 kt	98 - 184 km/h 53 to 99 kt
yellow radial: at VA maneuvering speed	159 km/h 86 kt	167 km/h 90 kt	179 km/h 97 kt
yellow arc: VNO to VNE operate with caution, only in smooth air	184 - 230 km/h 99 to 124 kt	184 - 230 km/h 99 to 124 kt	184 - 230 km/h 99 to 124 kt
red radial: at VNE max. speed for all ops.	230 km/h 124 kt	230 km/h 124 kt	230 km/h 124 kt

2.4. Power Plant Limitations

This is a summary of the respective engine manual. In case of any discrepancy the engine manual shall apply.

	ROTAX 912 UL	ROTAX 912 ULS
Oil	according ROTAX manual	
Oil level	2,6 Ltr (min) to 3,05 Ltr (max)	
Oil temperature	min 50°C, max. 140°C	min 50°C, max. 130°C
Oil pressure	1,5 bar to 5 bar (engine start 7 bar)	
Fuel	UL 91, MOGAS (TM-FK001-2011), AVGAS 100LL	
Fuel pressure	0,15 bar to 0,5 bar	
CHT	max. 120°C when using water / glycol mixture	

Note: Oil system, Engine lubrication system

Engines which have had the prop spun for more than 1 turn in reverse direction allow air to be injected into the valve train.

Action:

1. It is forbidden to spin the prop in reverse direction for more than 1 turn.
2. Inspection for correct venting of the oil system has to be performed in cases when the prop has been spun in reverse direction for more than 1 turn.

2.5. Propeller

Engine	Propeller	Diameter
ROTAX 912 UL	Warp / DUC 3 blades	1,72 m / 68 inch
ROTAX 912 UL	Helix 2 blades H50F	1,75 m / 69 inch
ROTAX 912 UL	Helix 3 blades H50F	1,75 m / 69 inch
ROTAX 912 ULS	DUR-3-165-C4-T	1,65 m / 65 inch
ROTAX 912 ULS	Warp / DUC 3 blades	1,72 m / 68 inch
ROTAX 912 ULS	Helix 2 blades H50F	1,75 m / 69 inch
ROTAX 912 ULS	Helix 3 blades H50F	1,75 m / 69 inch
ROTAX 912 ULS	DUR-3-170-C4-T	1,70 m / 66,9 inch

2.6. Service Ceiling

The maximum Altitude in ISA conditions at a weight of 472,5kg is:

Engine	ceiling	Please observe oxygen requirements and respect any local regulations and rules!
ROTAX 912 ULS	15000ft	
ROTAX 912 UL	13000ft	

Caution:

During flights above 7500ft (pressure altitude) the V_{NE} is reduced to 205km/h / 110kt.

2.7. Weights

Empty weight:	acc. actual weighing
max. weight with ROTAX 912S:	600 kg / 1322 lbs
max. weight with ROTAX 912:	540 kg / 1190 lbs
Minimum weight Pilot's seat:	60 kg / 132 lbs
Maximum weight per seat:	110 kg / 243 lbs
Baggage max (wingtank version):	35 kg / 77 lbs
Baggage max (fuselage tank vers.):	20 kg / 44 lbs

2.8. C.G. Limits

forward center of gravity:	0,240 m / 9,5 inch behind datum
aft center of gravity	0,456 m / 17,3 inch behind datum

Datum is the leading edge of the wing.

For weighing, the firewall has to be in the vertical position.

2.9. Maneuvers

The FK 9 is an approved Ultralight or Light Sport Aircraft (LSA), (USA according FAA S-LSA).

Acrobatic maneuvers, including spins, bank angles greater than 60°, as well as IFR and VFR night are prohibited.

Note regarding spins: In the light aircraft / ultralight category spinning is strictly prohibited and is not required to be demonstrated during flight test program.

Despite this, all FK aircraft have also been tested regarding their general spin characteristics. In general it is important to know that a spin is a very complex flight condition and relates to many individual factors like weight, centre of gravity, mass distribution, aerodynamic conditions, number of spin turns already performed, kind of control deflections already made and so on.

For example, the spinning characteristic of the same aircraft on the same day can differ significantly because of differences in mass distribution or dirt on surfaces. This can cause a "non recoverable" spin-condition!

In practice this means that flying into stalls on purpose must be avoided and recovery procedures have to be performed immediately!

Spinning any aircraft which is not certified for this maneuver is extremely dangerous! The onset of a stall is indicated to the pilot by many factors like IAS, stick pressure, horizon level. Stalls can also be result from abrupt control deflections / changes in angle of attack!

In strong turbulence the airspeed must be reduced below V_A .
When flying off grass strips with long grass, the wheel pants must be removed to avoid damage.

Maneuvers with zero or negative load factors must be avoided under all conditions. These maneuvers may cause a fire due to fuel spill when using ROTAX engines with carburetors.

2.10. Flight Load Factors

	positive	negative
Maximum load factor at V_A	+ 4g	- 2g
Maximum load factor at V_{NE}	+ 4g	- 1,5g
Maximum load factor with flaps down	+ 2g	0g

2.11. Kind of Operation

The FK 9 is approved as Ultralight or Light Sport Aircraft for daytime VFR.

2.12. Fuel

Capacity	total fuel capacity	total useable fuel
fuselage tank version	60 Ltr (15,8 USG)	57 Ltr (15 USG)
add. optional wing tanks	40 Ltr (10,5 USG)	36 Ltr (9,5 USG)
wing tank version	110 Ltr (29 USG)	105 Ltr (27,7 USG)

Approved Fuel Grades:

- Unleaded fuel recommended
- UL 91
- MOGAS (with regard to TM-FK001-2011)
- AVGAS 100LL

AVGAS should only be used if no other fuel is available or in case of problems caused by vapour locks (check engine manual).

Wingtank version:

Max 15 Ltr (4 USG) difference between left/right tank.

No takeoff on a tank selected which contains less than 15 Ltr (4 USG) of fuel.

Engine operating manual is the governing one!

2.13. Passenger Seating

The aircraft has 2 seats. It can be flown from either seat.

2.14. Colour

The surface of the structure (composite structure) must be white or yellow. Local coloured decoration is possible. Complete painting in different colours only with agreement of the manufacturer.

2.15. Electric

The electrical system is designed for a maximum load of 12 A.

2.16. Power Plant Instrument Marking

ROTAX 912 / 912S

Instrument	Units	Red line	Green arc	Yellow arc	Red line
		Lower limit	Normal range	Caution range	Upper limit
RPM	RPM	-	1400 - 5500	5500 - 5800	5800
Oil temp.	°C	-	90 – 110	50- 90 110 – 130	130
	°F	-	194- 230	122 – 194 230 - 266	266
Oil press.	bar	0.8	2 - 5	0,8 – 2 5 - 7	7
	PSI	12	29 - 73	12 -29 73 -102	102
Fuel press	bar	0.15	0.15 – 0.5	-	0.5
	PSI	2.2	2.2 – 7.3	-	7.3
Cylinder head temp	°C	-	-	-	120
	°F	-	-	-	248

2.17. Placards

Location:	Placard:
Baggage compartment	max. load 35 kg / 77 lbs (wing tanks) max. load 20 kg / 44 lbs (fuselage tanks)
Brake handle	Brake
Brake park valve	Park
Cabin heat	cabin heat (option)
Carburetor heat	carb. (option)
Choke	choke
Cockpit	max. TOW _____ kg / lbs spins and acrobatics prohibited
Cockpit	Weighing date: Empty weight: Poss. load including fuel:
Cockpit	"This aircraft was manufactured in accordance with Ultralight / Light Sport Aircraft airworthiness standards and does not conform to standard category airworthiness requirements"
Instrument panel	above 7500ft PA Vne = 205 km/h
Door handles (inside + outside)	OPEN / CLOSE
Fuel selector(s) in flow direction	fuel
Fuel selector(s) closed position	close
Fuel return closed position	close
Fuel cap(s)	FUEL AVGAS / MOGAS / UL91
Fuel indication	markings every 10 ltr (2,5 USG)
Fueselage below stabilizer	Type placard (metal)
Rescue system (vicinity)	placard Rescue system
Rocket Exit Area	Danger: Rocket Exit Area
Safety pin rescue system	Remove before flight
Top of vertical fin	Company logo
Throttle friction	throttle friction
Trim handle	trim
Trim markings	Neutral; nose up; nose down
VDO Oil temperature indication (no EMS)	OIL
VDO CHT indication (no EMS)	CHT
Wheel fairings main wheels	2,8 bar / 41 psi
Wheel fairing nose wheel	1,8 bar / 26 psi
Towing version only:	
Handle for cowlfap	Cowlfap
Handle for towing clutch	TOW
Towing clutch	max. break load 200 kp / 440 lbs
Vicinity of airspeed indicator	Care for tow speed !

3. Emergency Procedures

3.1. General

The following information is presented to enable the pilot to form, in advance, a definite plan of action for coping with the most probable emergency situations which could occur in the operation of the airplane.

3.2. Airspeeds for Emergency Procedures

recommended speeds	472,5kg 1042 lbs	525kg 1157 lbs	600kg 1323 lbs
V glide flaps 1:	100 km/h / 54 kt	105 km/h / 57 kt	115 km/h / 62 kt
V app flaps up	110 km/h / 59 kt	115 km/h / 62 kt	125 km/h / 67 kt
V app flaps 1	105 km/h / 57 kt	110 km/h / 59 kt	115 km/h / 62 kt
V app flaps 2	95 km/h / 51 kt	100 km/h / 54 kt	105 km/h / 57 kt

Glide ratio is about 1:8,5.

3.3. Engine / Carburetor Fire

Fuel selector (s)	OFF
Fuel return	closed
Throttle	full open
electrical fuel pump	OFF
cabin heat	OFF
if required (on ground only):	
Starter	engage
after engine stops:	
Ignition & battery switch	OFF
On ground:	leave airplane, try to extinguish fire
In flight:	perform Emergency Landing Proc.

3.4. Engine Failure

during takeoff run:

Throttle	idle
Brakes	as required
<i>aircraft stopped:</i>	
Electrical fuel pump	OFF
Fuel selector(s)	OFF
Fuel return	closed
Ignition	OFF
Battery switch	OFF

in flight:

Glide speed	V glide (flaps pos. 1)
Electrical fuel pump	ON
Fuel selector(s)	check ON (fullest tank ONLY)
Ignition	check ON
Engine	start
No restart possible:	
Emergency landing	perform respective procedure

3.5. Emergency Landing

without Engine Power:

Glide speed	V glide (flaps pos. 1)
Emergency field	select
Emergency call (121,5 MHz)	perform
Throttle	idle
Electrical fuel pump	OFF
Fuel selector(s)	OFF
Fuel return	closed
Ignition	OFF
Safety belts	pull tight
Final, landing assured:	
Flaps	full down
Battery switch	OFF
Approach speed	V app according flaps

The glide can be controlled by changing airspeed, flap setting or slip. Use caution, flaps in position 2 cause a lot of drag. Airspeed indication remains valid during slip. Touchdown should be achieved at minimum speed.

Engine Power available:

Emergency field	select
Emergency call (121,5 MHz)	perform
Safety belts	pull tight
Normal landing	perform

3.6. Emergency Descent

Throttle	idle
Flaps	retracted (up)
Airspeed	max V_{NE}

3.7. Strong Vibrations

Caused by engine or propeller:	
Ignition	OFF
Airspeed	reduce
Emergency landing	perform respective procedure
Caused by the fuselage / wings:	
Airspeed	reduce

3.8. Steering Problems

Aircraft uncontrollable with remaining flight controls:	
Throttle	idle
Ignition	OFF
Rescue system	activate
Electrical fuel pump	OFF
Fuel selector(s)	OFF
Fuel return	closed
Emergency call (121,5 MHz)	perform
Battery switch	OFF
Safety belts	pull tight
Doors	unlatch

3.9. Flap Failure

If the regular flap control fails, the flaps can be moved to the full up and full extend positions by rotating the flap selector to the respective end positions.

3.10. Oil Pressure Low

Oil pressure indicator	check
Throttle	min. necessary power
if oil pressure still low	perform precautionary landing

3.11. Fuel Pressure Low

electrical fuel pump	ON
fuel selector	check ON
Wingtank version	Select fullest tank ONLY

3.12. Generator Fault

In the event of a power generator fault, switch OFF all non-essential devices in order to save battery power.

3.13. Fire and Smoke (Electric)

All electrical systems	OFF
Landing	as soon as possible; if required, perform emergency landing
Rescue system	activation only, if immediate emergency landing not possible

3.14. Stall recovery

A stall can be recognized by light buffeting.

Elevator	push
Wings	level
Aircraft	recover

Normally the FK 9 does not enter a spin out of a slowly initiated stall.

Spin recovery (if a spin is entered inadvertently):

Power	idle
Stick	neutral
Full rudder	opposite to direction of spin
Flaps	up
Wings	level
Aircraft	recover

To avoid overstressing the flaps, they must be retracted immediately.

Stalls (especially with power on), spins and all maneuvers with zero or negative g-load must be avoided under all circumstances, these maneuvers may cause a fire, especially when using ROTAX engines with carburetors.

For all other emergencies use standard procedures!

4. Normal Procedures

4.1. General

This chapter deals with the normal procedures recommended for the safe operation of the FK 9.

4.2. Recommended Speeds

recommended speeds	472,5kg 1042 lbs	525kg 1157 lbs	600kg 1323 lbs
Vr	100 km/h / 54 kt	100 km/h / 54 kt	100 km/h / 54 kt
V climb flaps 1	105 km/h / 57 kt	110 km/h / 59 kt	115 km/h / 62 kt
V climb flaps up	110 km/h / 59 kt	118 km/h / 64 kt	135 km/h / 73 kt
V app flaps up	110 km/h / 59 kt	115 km/h / 62 kt	125 km/h / 67 kt
V app flaps 1	105 km/h / 57 kt	110 km/h / 59 kt	115 km/h / 62 kt
V app flaps 2	95 km/h / 51 kt	100 km/h / 54 kt	105 km/h / 57 kt

4.3. Regular Inspection

If there is any damage it is recommended to consult a certified maintenance facility or contact the manufacturer. This applies especially to the composite and aluminium structures.

4.4. Preflight Inspection

During preflight inspection, the aircraft must be inspected for its general condition. Snow, ice, frost and dirt must be removed completely from the aircraft as they impair aerodynamics and also increase weight.

Items marked by * must be performed prior first flight of the day only.

Preparation	
* Aircraft condition	airworthy, papers available
Weather	sufficient
Baggage	weighted and safely stowed
Weight and balance	checked
Navigation and charts	prepared and available
Performance and endurance	calculated and safe

Cockpit	
Battery / ignition	OFF
Cabin	no loose objects
* Flight controls	connected and secured
* Belts, seats	check
Fuel quantity	check

Engine check (also perform the checks required as mentioned in the engine manual)	
* Cowling	remove
* Exhaust	check for cracks + check springs
* Carburetor, accessories	check
Coolant	check, add if required
Oil quantity	check, add if required
* Oil-, cooling- and fuel system	check for leaks
* Spark plugs	check
* Engine mount	check for cracks
* Vibration damper	check for cracks
* Fuel lines	check for damage
* Gascolator	drain fuel to check for contamination
* Cables, bowden-cables	check for damage
* Cowling	install
Cooling system / air inlets	clean, inlets clear

Outside check	
Wings, fuselage and rudder must be checked for damage.	
1. Engine	perform check as prescribed above
2. Propeller	no damage, cracks
3. Nose wheel	wheel fairings check; * tire press. 1,8 bar (26 psi)
4. Right landing gear	wheel fairings check; *tire press. 2,8 bar (41 psi); check main attachment screws
5. Right strut	* bolts secured, no damage
6. Right wing	clean, no damage
7. Aileron Counter weight	tight, no play
8. Aileron hinge	* secured
9. Wing bolts	* secured
10. Fuel cap(s), Drain	closed (wingtank: check both caps); * drain fuel to check for contamination
11. Right elevator	clean, no damage, freedom of movement; * connections OK + secured
12. Rudder	clean, no damage, freedom of movement; * connections OK + secured
13. Left elevator	clean, no damage, freedom of movement; * connections OK + secured
14. Antenna, baggage door	tight, check closed
14a. Static port (incl. drain)	clear
15. Wing bolts	* secured
16. Aileron hinge	* secured
17. Aileron Counter weight	tight, no play
18. Left wing	clean, no damage
19. Left strut	* bolts secured, no damage; pitot tube clear, cover removed
20. Left landing gear	wheel fairings check; * tire press. 2,8 bar (41 psi); check main attachment screws
Tail wheel only	
tailwheel	wheel OK; * connection OK + secured

Preflight Check

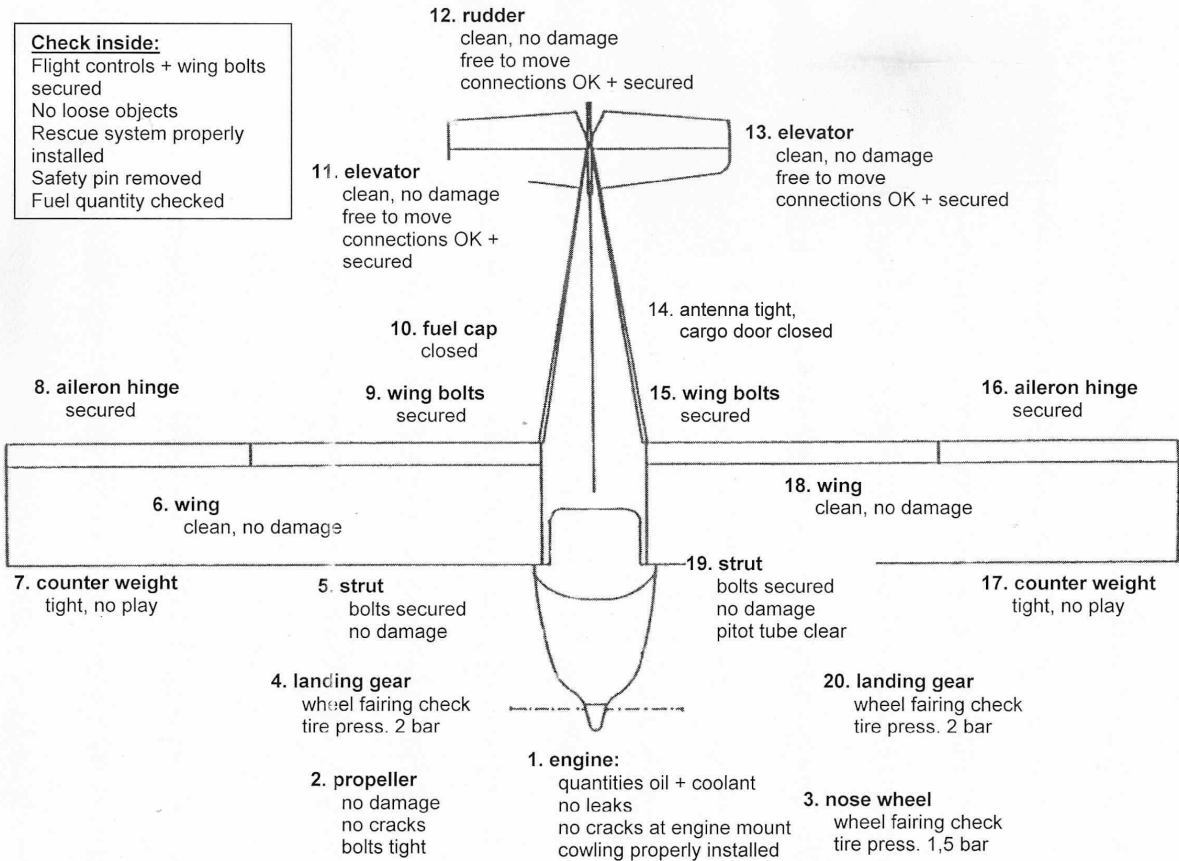

4.5. Engine Start

Seat belts	fastened
Doors	closed and locked
Fuel selector(s)	OPEN, wingtank: only fullest tank OPEN (both full => left tank OPEN)
Fuel return	open
<i>no TAKEOFF on a tank containing less than 15 Ltr / 4 USG</i>	
all electrical equipment	OFF
Circuit breaker	check
Rescue system	check safety pin removed
Battery switch	ON
Ignition	ON
Electrical fuel pump	ON
Choke	pull (cold engine only)
Parking Brake	set
Throttle	idle
Prop area	CLEAR
Starter	engage; set 2000 RPM
Oil pressure	check
Choke	OFF
Electrical fuel pump	OFF
Avionics	ON
Instruments	check & set

4.6. Taxi

Brakes	check
Stick / Control wheel	according wind situation
Rudder	do not move if aircraft is not moving

4.7. Before Take-off

Brakes	set
Instruments	check
Magnetos	check at 4000 RPM; variance between mags. max. 115 RPM, max. drop 300 RPM
Electrical fuel pump	ON
Carburetor heat	OFF (if installed)
Flaps	takeoff position (Pos. 0 or 1)
Flight controls	check
Trim	set
Doors	closed and locked; end of seatbelts inside the cockpit
Oil temperature	min. 50°C / 122°F
CHT	min. 60°C / 140°F

4.8. Takeoff

Brakes	released
Throttle	advance slowly to full power
Engine instruments	check, min. 4500 RPM
Elevator	neutral
at rotation speed Vr	rotate
Climb	Vcl (speeds according table chapter 4.2)
Clear of obstacles, at safe altitude & speed:	
Flaps	up
Electrical fuel pump	OFF
Fuel return	close (check chapter 7)

It is not recommended to takeoff with full flaps as the flaps produce a lot of drag in this position.

4.9. Climb

Oil temperature	max. 130°C / 266°F
CHT	max. 120°C / 248°F

Hint:

CHT >115°C / 239°F might cause continuous loss of cooling fluid via the overflow bottle. Reduce power setting and increase airspeed until CHT remains below 115°C / 239°F.

4.10. Cruise

Oil temperature	max. 130°C / 266°F
CHT	max. 120°C / 248°F
Trim	set
Fuel	monitor Wingtanks: switch tanks at least every 60 min; max. 15 Ltr / 4 USG difference between tanks

For values of fuel flow and range check chapter 5.

4.11. Descent

Carburetor heat (if installed)	ON
Fuel selector(s) wingtanks	only fullest tank OPEN
Oil temperature	min. 50°C / 122°F
CHT	min. 60°C / 140°F

Hint:

If engine temperatures remain at or below minimum values during flight (winter operation), it is recommended to mask the radiators with tape.

4.12. Landing (speeds according table chapter 4.2)

Speed	reduce below 130 km/h / 70 kt
Normal landing	use flaps 0 or 1
Short field landing	use flaps 2
Speed on final	Vapp according flaps (rain + 5km/h / 3 kt)
Electrical fuel pump	ON
Fuel return	open
Short prior touchdown	flare to achieve touchdown at min. speed
Throttle	idle
Tail wheel only	
Touchdown	in 3 point position
Control stick / wheel	keep full aft after tail wheel is on the ground
Go Around	
Throttle	advance slowly to full power
Speed	min. 105 km/h / 57 kt
Flaps	retract to / maintain Pos. 1
Carburetor heat (if installed)	OFF
Trim	set
Clear of obstacles, at safe altitude:	
Flaps	up
Electrical fuel pump	OFF
Speed	Vcl flaps up

,

4.13. Balked Landing

Throttle	max. power
Airspeed	min. 105 km/h / 57 kt
Flaps	1
Carburetor heat (if installed)	OFF
Trim	as required
Clear of obstacles, at safe altitude:	
Flaps	up
Electrical fuel pump	OFF
Speed	Vcl flaps up

4.14. Touch and Go

Flaps	retract to Pos. 1
Carburetor heat (if installed)	OFF
Trim	set takeoff position
Throttle	advance slowly to full power
at 100 km/h / 54 kt	rotate
Speed	Vcl flaps 1
Clear of obstacles, at safe altitude:	
Flaps	up
Electrical fuel pump	OFF
Speed	Vcl flaps up

4.15. After Landing / Parking

Flaps	up
Trim	neutral
Carburetor heat	OFF (if installed)
Electrical fuel pump	OFF
Avionics	OFF
Ignition	OFF
Battery switch	OFF
Rescue system	secure (insert safety pin)
Fuel return	close

It is recommended to secure the aircraft:

- insert chocks
- flight controls can be locked by using the seatbelts

5. Performance

5.1. General

The graphs and tables in this section present performance information corrected for the conditions of ICAO Standard Atmosphere. These data do not contain any safety margin and are based on a clean and well serviced aircraft as well as the compliance with aforementioned procedures.

5.2. Takeoff Distance

Conditions: Mean sea level (MSL), no wind, dry grass surface, takeoff weight, flaps pos. 1. Valid for all fixed pitch propeller.

Engine	Mass	Takeoff run	to 50 ft Height
ROTAX 912 UL	472,5 kg / 1042 lbs	106 m / 348 ft	265 m / 869 ft
	525 kg / 1157 lbs	140 m / 459 ft	350 m / 1148 ft
	540 kg / 1190 lbs	147 m / 482 ft	367 m / 1204 ft
ROTAX 912 ULS	472,5 kg / 1042 lbs	100 m / 328 ft	225 m / 738 ft
	525 kg / 1157 lbs	128 m / 420 ft	320 m / 1050 ft
	540 kg / 1190 lbs	136 m / 446 ft	338 m / 1109 ft
	570 kg / 1257 lbs	141 m / 463 ft	352 m / 1152 ft
	600 kg / 1323 lbs	153 m / 502 ft	375 m / 1230 ft

Correction for differing conditions:

Correct above mentioned values for differing conditions as follows:

Difference in	Correction	m
1. Pressure Altitude:	+ 10% per 1000ft Pressure Altitude (PA)	+ =
2. Temperature:	+/- 1% per°C temperature deviation	+/- =
3. Slope:	+/- 10% per 1% slope	+/- =
4. wet surface:	+ 10 %	+ =
5. soft surface:	+ 50%	+ =
6. high grass:	+ 20%	+ =

5.3. Climb Performance

in ISA conditions, flaps up, all fixed pitch propeller

	Rotax 912		Rotax 912S	
mass	speed	climb rate	speed	climb rate
472,5kg	110 km/h 59 kt	4,9 m/s 965 ft/min	110 km/h 59 kt	6,2 m/s 1220 ft/min
525kg	118 km/h 64 kt	4,0 m/s 787 ft/min	118 km/h 64 kt	5,4 m/s 1063 ft/min
540kg	120 km/h 65 kt	3,9 m/s 760 ft/min	120 km/h 65 kt	5,2 m/s 1024 ft/min
600kg			135 km/h 73 kt	4,3 m/s 854 ft/min

5.4. Cruise Performance

at a weight of 472,5kg in ISA conditions

	Rotax 912		Rotax 912S	
PWR	speed	fuel flow	speed	fuel flow
55% 4300RPM	155 km/h 84 kt	11,5 l/h 3,04 USG/h	165 km/h 89 kt	14,5 l/h 3,83 USG/h
65% 4800RPM	175 km/h 94 kt	14,5 l/h 3,83 USG/h	185 km/h 100 kt	17,5 l/h 4,62 USG/h
75% 5000RPM	185 km/h 100 kt	16 l/h 4,23 USG/h	195 km/h 105 kt	19 l/h 5,02 USG/h

5.5. Landing Distance

Conditions: Mean sea level (MSL), dry grass surface, no wind, full flaps, land normal braking.

Mass	Landing distance from 15m / 50ft	ground roll
472,5 kg	263 m / 863 ft	98 m / 322 ft
600 kg	385 m / 1263 ft	155 m / 509 ft

Correction for differing conditions:

Correct above mentioned values for differing conditions as follows:

Difference in	Correction	m
1. Pressure Altitude:	+ 5% per 1000ft Pressure Altitude (PA)	+ =
2. Temperature:	+/- 0,5% per°C temperature deviation	+/- =
3. Slope:	+/- 10% per 1% slope	+/- =
4. wet surface:	+ 15 %	+ =
5. snow surface:	+ 25%	+ =
6. high grass:	+ 20%	+ =

6. Weight and Balance

6.1. General

To achieve the mentioned performance data and flying abilities, the aircraft must be operated within certified weight and balance limits. Although the aircraft has a wide range for weight and balance, it might be not possible to fly with full baggage load, full fuel and 2 heavy pilots at the same time.

Wrong loading has consequences for every airplane:

an aircraft exceeding weight limits will need longer takeoff- and landing distances, climb performance will be decreased and stall speed increased.

A wrong center of gravity will change flight characteristics. A forward C.G. may cause problems during rotation, takeoff and landing. An aft C.G. may cause instability, inadvertent stall or even spin.

The pilot in command must ensure prior to each takeoff, that the aircraft is operated within the certified weight and balance limits.

6.2. Basic Empty Weight

Prior to delivery, each aircraft has been weighted with fuselage level, (reference line see drawing below, firewall vertical), including oil and coolant, as well as equipment as indicated but no fuel (except un-drainable fuel). During this procedure the respective arms are determined as well.

By using the following formula, the C.G. is computed. Reference line (datum) for all arms is the leading edge of the wing. All these data are transferred to the Basic Empty Weight and Balance Form (Wägebericht). This "Wägebericht" contains a list of equipment installed and is part of this manual.

All changes to the airplane affecting weight and balance (installation of new equipment etc.) require a new weighing.

Formula to compute the center of gravity (X):

Center of Gravity in [m / inch] $CG = \frac{\sum M}{\sum G}$

TW = total weight
WF = weight front
WR = weight right
WL = weight left

$X[m / inch] = \frac{-L1 \cdot WF + L2 \cdot (WR + WL)}{TW}$

Tricycle

$X[m / inch] = \frac{(WR + WL) \cdot L1 + WA \cdot L2}{TW}$

Tailwheel
WA = weight aft

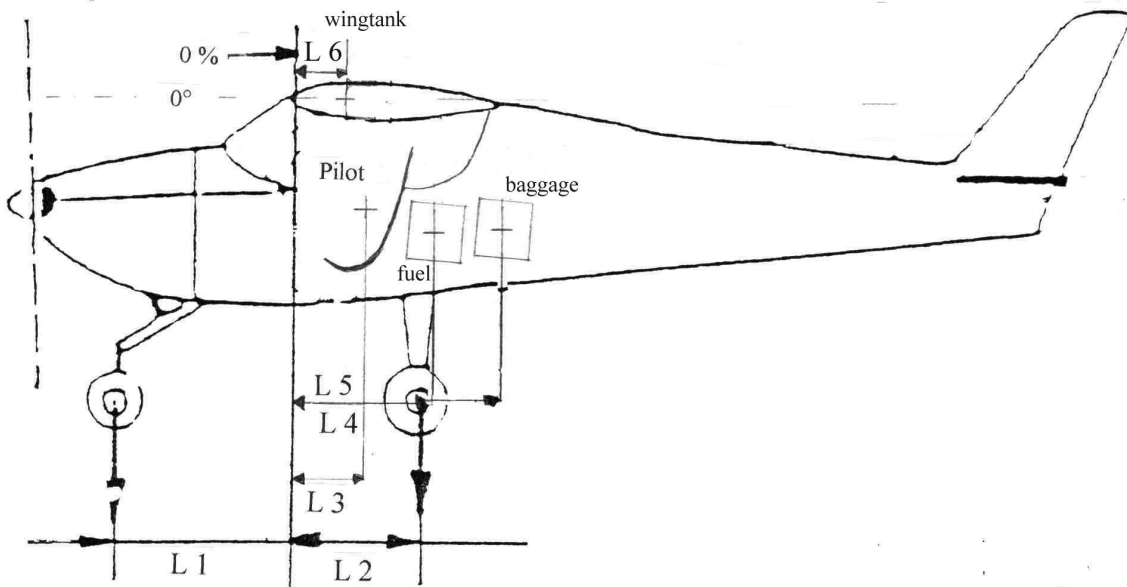

Arms (Datum: wing leading edge):

L 1 nosewheel	Weight form	L 4 fuselage tank	0,97m / 38,19 inch
L 2 wheel	Weight form	L 5 baggage	1,38m / 54,33 inch
L 3 seat	0,46m / 18,11 inch	L 6 wingtank	0,58m / 22,83 inch

6.3. Determination of C.G. for the Flight

The Pilot is responsible for proper loading of the aircraft.

The C.G. can be determined by computation. The C.G. must always be within limits (compare chapter 2)!

Example for computation:

Data in the shaded area are taken from the "Wägebericht".

Position	Weight [kg]	Arm [m]	Moment [mkg]
Left wheel	WL = 120,1	L 2 = 0,527	63,29
Right wheel	WR = 119,1	L 2 = 0,527	62,77
Nose wheel	WF = 45,8	L 1 = - 0,854	- 39,11
Empty weight-data	Empty weight 285	C.G. 0,31	86,95
Pilot(s)	150	L 3 = 0,46	69
Fuel fuselage	10	L 4 = 0,97	9,7
Fuel wing	0	L 6 = 0,58	0
Baggage	5	L 5 = 1,38	6,9
Total	Total Weight 450	C.G. (0,24 to 0,456) 0,383	Total Moments 172,55

Form:

Position	Weight []	Arm []	Moment
Left wheel	WL = _____	L 2 = _____	_____
Right wheel	WR = _____	L 2 = _____	_____
Nose wheel	WF = _____	L 1 = _____	_____
Empty weight-data	Empty weight	C.G.	
Pilot(s)	_____	L 3 = _____	_____
Fuel fuselage	_____	L 4 = _____	_____
Fuel wing	_____	L 6 = _____	_____
Baggage	_____	L 5 = _____	_____
Total	Total Weight	C.G. (0,24 to 0,456)	Total Moments

7. Systems Description

7.1. General

The FK 9 is a two-seat high wing aircraft with aerodynamic steering. It is available in tricycle or tailwheel configuration. The wing has flaps which can be set to three positions. The nosewheel / tailwheel is steerable and connected to the rudder pedals. The aircraft is equipped with dual controls.

7.2. Instrument Panel

The instrument panel contains all required flight and engine instruments. This picture shows a more advanced equipment configuration. Different instrument options are available on request.



- 1 Headphone socket
- 2 Electric panel
- 3 EFIS
- 4 EMS

- 5 Speed indicator
- 6 Altimeter
- 7 MID
- 8 GPS

- 9 Radio
- 10 Transponder

Center Console

Controls to operate flaps, brakes, trim and light switches are located at the center console.

With fuselage tanks installed, the fuel selector can be found at the console as well and the fuel return valve is installed left of it.

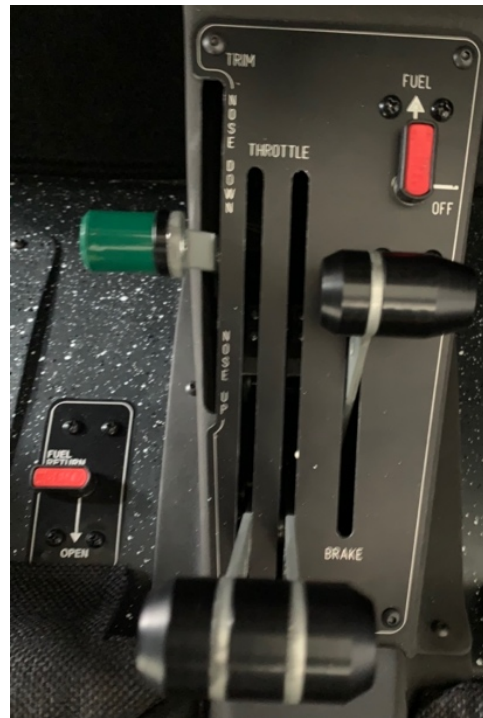

Wingtank version: the fuel selectors are installed at the respective A-pillar and the fuel return is located at the left wing root above the door.



fuel return valve



fuel valve

7.3. MID (Multi Information Panel)

The MID provides:

- Checklists
- Door status
- Fuel consumption + status
- Flap status
- Maintenance Intervals
- OAT
- System Warnings
- Time
- Voltage



Handling MID

+	increase value / up
Set	short press = 1 beep = acknowledge long press = 2 beeps = page change
-	decrease value / down

Screen Rotation

<p>WELCOME ON BOARD D-MXXX</p> <p>NEXT MAINT.: 24:40h ENGINE TOTAL: 0:20h</p> <p>DATE: 5.10.09 U1.1</p>	<p><u>splash screen:</u></p> <ul style="list-style-type: none"> • callsign • time to next maintenance • engine total time • date • software version <p>values are changeable via SETUP screen changes after long press of "Set"</p>
	<p><u>normal screen (engine off):</u></p> <ul style="list-style-type: none"> • fuel (wingtanks option L+R) • flap position • door status • voltage • outside air temperature • time

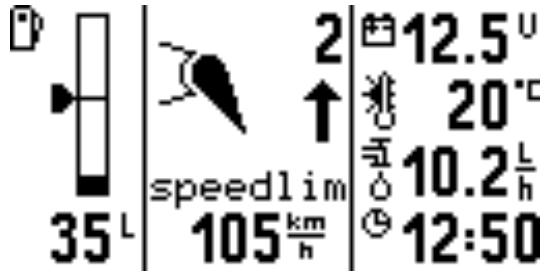
 <p>The normal screen (engine running) displays the following information: fuel gauges (35 L and 105 km/h), speed limit (105 km/h), altitude (12.5 U), outside air temperature (20°C), fuel flow (10.2 L/h), and time (12:50).</p>	<p><u>normal screen (engine running):</u></p> <ul style="list-style-type: none"> • fuel (wingtanks option L+R) • flap position • speed limit at current flaps • voltage • outside air temperature • fuel flow (if installed) • time
<p>CHECKLISTS: ENGINE START: BEFORE TAKE-OFF CRUISE BEFORE LANDING PARKING</p>	<p><u>checklist screen:</u> using the “+” or “-” buttons the cursor can be set to the desired checklist; pressing “Set” executes the selection. the handling of the checklist itself works similar; the checklist page will be left after completion of all items of the list or by keeping “Set” pressed for a longer time</p>
<p>⚠ WARNING ⚠ BATTERY LOW</p> <p>SWITCH OFF NON-ESSENT EQUIPMENT AND CHECK REGULATOR + GENERATOR</p>	<p><u>warning / failure screens:</u> following warnings / failures can be displayed:</p> <ul style="list-style-type: none"> • fuel gage / fuel low • fuel pressure low • flap setting • battery low / overcharge • door left / right • generator <p>messages can be acknowledged by pressing “Set”</p>

SETUP MENU	use “+” and “-“ to highlight the desired menu, press “Set”; use “+” and “-“ to change the item, acknowledge by “Set”; repeat as required
FUEL CONTENT xxxl	enter actual fuel on bord; fuel remaining will be calculated by using fuel flow; if a fuel level sensor installed, remaining fuel is given by the sensor
FLOW FACTOR xxx%	the fuel flow indication can be calibrated by changing the flow factor: measured fuel flow 10% less than indicated => set factor 10% higher
RES.MAINT.TIMER Y/N	“Y” resets the maintenance counter to 50h
SET TIME xx:xx	enter actual time, format hh:mm
SET DATE xx.xx.xxxx	enter actual date, format dd.mm.yyyy
DOOR WARNING Y/N	“Y” if door warning installed
CALIB TANK EMPTY Y/N	“Y” calibrates the fuel sensor to empty tank
CALIB TANK FULL Y/N	“Y” calibrates the fuel sensor to full tank
TANK VOLUME xxxl	set tank volume; no fuel display if “0” entered
RESERVE VOLUME xxl	enter “0” if no fuel level sensor installed; enter fuel not sensed by fuel level sensor
REGISTRATION xxxxx	enter aircraft registration
SYSTEM SETUP ****	calibration settings protected by PIN
RESET TOTAL TIME x	to reset total engine time to zero, toggle to “Y”, and enter with “SET”: acknowledge “SURE” by holding “+” and “-“ depressed while pushing “Set”

7.4. Rescue system

The FK 9 may be equipped with an optional rescue system mounted inside the fuselage behind the seats. Only original Kevlar harness parts must be used. There must be no obstructions for the deployment of the rocket. Detailed information concerning max. speed, capacity and maintenance cycles are provided in the respective rescue system manual.

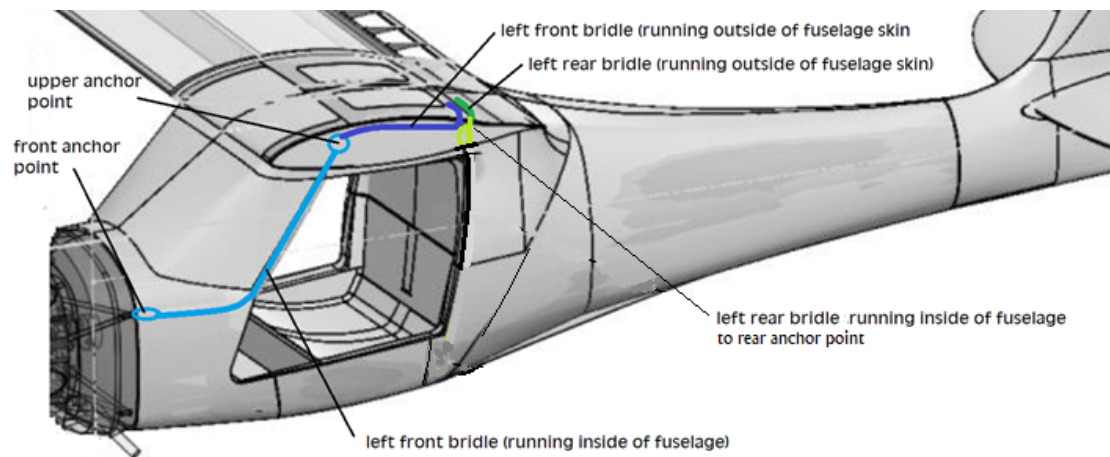

The system is activated by pulling the red handle at the center console. *The safety pin **must** be removed before flight.* The safety pin should be inserted again during storage / parking of the aircraft to avoid inadvertent activation.

7.5. Flaps

The flaps are operated electrically by a lever at the center console. The current flap position is indicated either by the MID or by other electronic display systems. In case of a flap position sensor failure, the flaps can be selected to the up or fully extend position by turning the lever left of "0" (up) or right of "2" (down).

7.6. Tyres

Wheel	Size	Pressure
Main tailwheel only option	6.00 x 6 or 4.00 x 6 6.00 x 8	2,8 bar / 41 psi
Front	4.00 x 4	1,8 bar / 26 psi
Tail	125 mm / 4,92 inch	

7.7. Baggage

There is one baggage compartment aft of the pilots seats accessible from the outside by a baggage door. It has a maximum capacity of 77 lbs (35 kg) lbs with wingtanks and 20 kg / 44 lbs with fuselage tanks installed. Smaller items must be put into bags. All things in the baggage compartment should be secured in order not to move around.

7.8. Seats and seatbelts

The backrests of the seats can be adjusted. The locking mechanism behind the headrest must first be released to allow adjustment of the lower part of the backrest to the desired position. The upper part can then be locked as desired. For taller pilots, the backrest can be removed completely. The 4-point seatbelts can be adjusted to fit every size. The lock is released by pressing the red button.



7.9. Doors

The doors can be opened and closed with a handle. Both doors have a small perspex vent.

7.10. Engine

The engine is a ROTAX 912 / 912S. It has a combined cooling by liquid and air. To shutdown the engine it is recommended to switch off one ignition circuit by using the ignition test switch before shutting down the engine completely.

The control lever for choke is located below the instrument panel. Throttle and carburetor heat (if installed) handles are at the center console.

The engine cowling can easily be removed for maintenance and checks. Oil and coolant can be checked by opening a small cap on the right upper part of the cowling.

7.11. Propeller

There are different propeller available for the FK 9. For details check the respective manual.

7.12. Fuel System

The FK 9 is equipped either with fuselage (Option 1) or with wing tanks (Option 2). There is one engine - mounted mechanical fuel pump which normally provides fuel to the engine. *Additionally there is an AUX electrical fuel pump which should be ON during takeoff and landing.*

Fuel return

A fuel return line is installed from the carburetors to the left fuel tank. The respective fuel return valve should be open for engine start, takeoff and landing to avoid fuel vapor lock. It can be closed during cruise flight to allow precise data of an optional installed fuel flow transducer.

Drainventile / Gascolator

There is a drain valve installed in every tank. Additionally, a gascolator is mounted in the engine compartment.

Therefore fluid can be drained from the fuel system to check for possible contamination with water.

Fuel low Pressure Warning:

One (optional) fuel pressure warning light, the MID or the EMS indicate fuel pressure below minimum. In this case, switch ON the electrical fuel pump and select the fullest tank.

Fuel Quantity Indication:

Beside the visual gauge at the fuselage tank, there is an additional fuel quantity indication (analog / MID / EMS). This indication derives the information from two different sources, depending on the system installed:

- a) the pilot enters the fuel quantity before takeoff and the MID / EMS computes the remaining fuel using the fuel flow sensor
- b) fuel level sensors are installed in the tank and transmit fuel quantity to the analog gauge / MID / EMS

The fuel quantity indication offers a rough estimate of the current fuel on bord. The accuracy of the system is not sufficient for flight planning purposes.

Option 1 Fuselage Tanks:

The two fuel tanks are mounted behind the pilot's seat. The fuel valve is located at the center console with positions ON and OFF. The fuel drain valve is located at the lower fuselage aft of the main landing gear for checking fuel purity.

Fuel quantity is indicated by a gauge at the tank. After refuelling, this indication is accurate after both tanks have levelled. This can take up to 5 minutes.

Although the fuel cap has a water drain, it is recommended to protect the cap to prevent water entering during strong rain by putting an extra cover on top of the cap when the aircraft is parked.



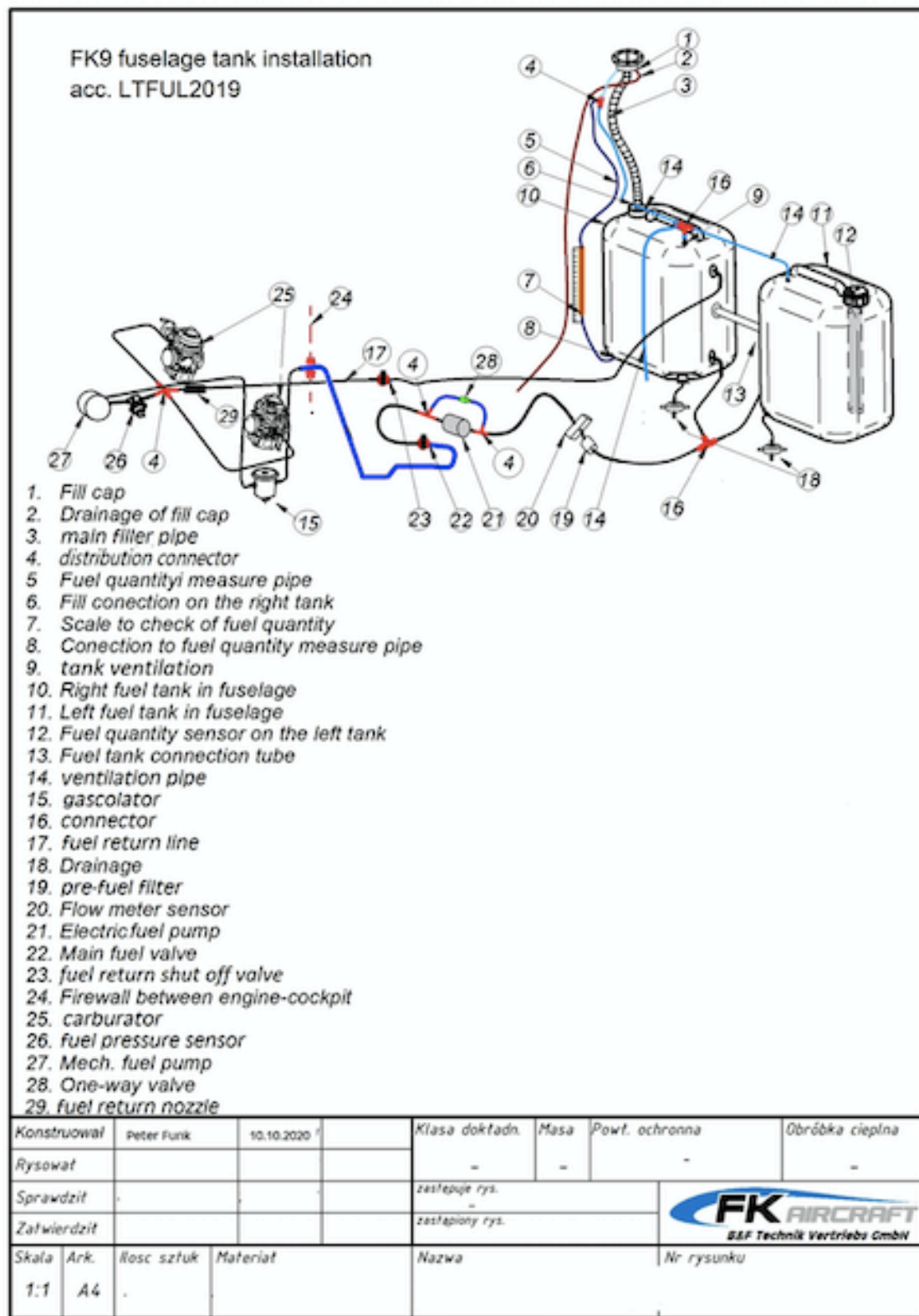

Additional Wingtanks (with fuselage tanks installed, optional)

Additional flexible fueltanks (capacity 20 Ltr / 5,28 USG each) can be installed in the wings of the FK 9. They are connected to the main tank and are filled and emptied by using an electrical pump. The overflow / vent (23) is connected to the vent system (8) of the main tank. Each tank has a fuel valve (19).

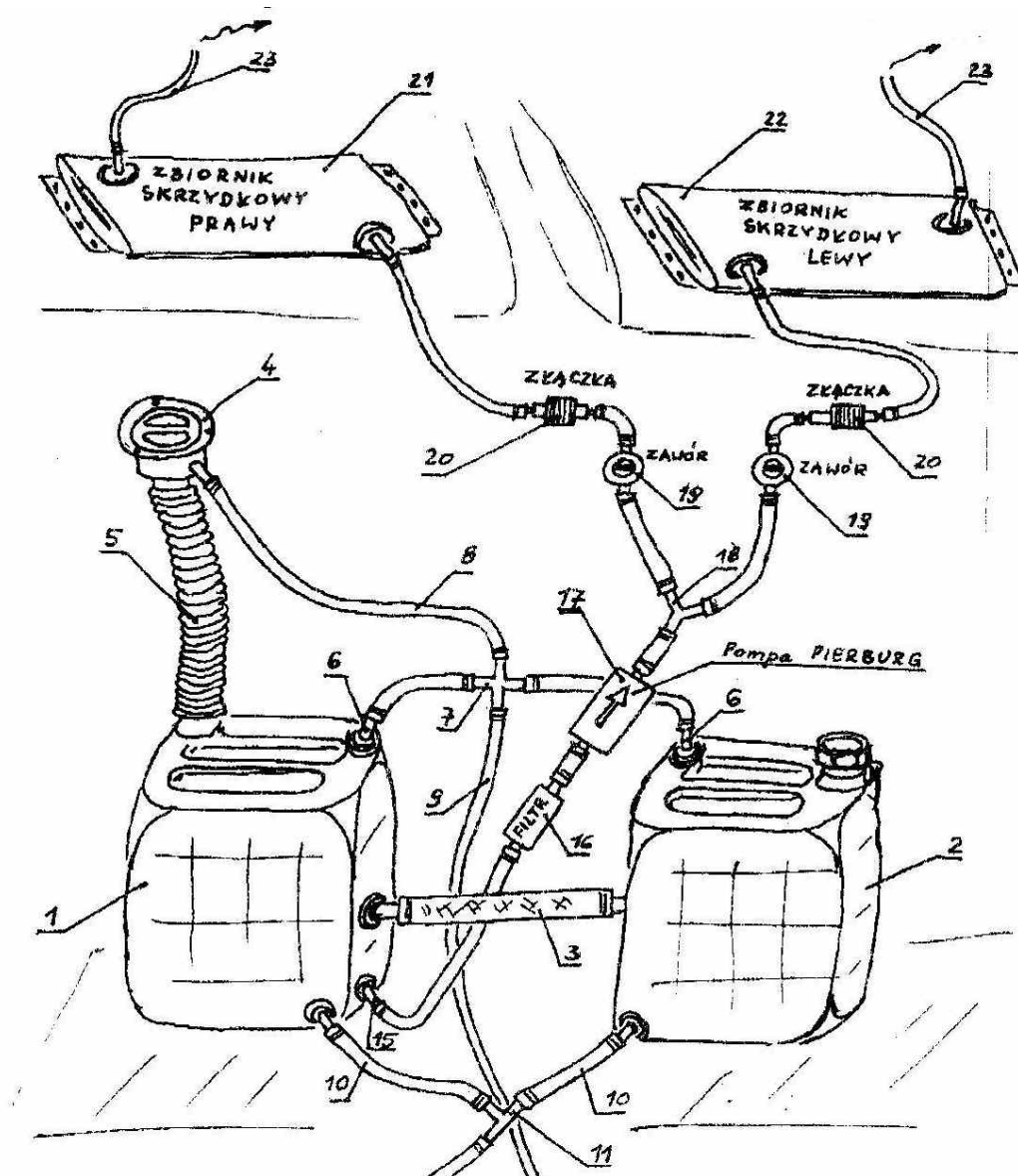

Handling of the additional wingtank:

To fill or empty the tank, the respective fuel valve (19) must be open and the pump must be switched to the "up" or "down" position.

Filling of the wintank has to be done on ground with at least 20 Ltr / 5,28 USG of fuel in the main tank. The wingtank is full as soon as fuel is flowing via the overflow / vent (23) into the vent system (8) of the main tank. Now the pump has to be switched off and the valve must be closed.

During flight, the fuel can be pumped out of the wingtank as soon there is space for at least 20 Ltr / 5,28 USG in the main tank.



Option 2 Wing Tanks:

There are two wingtanks installed. Each tank has a fuel valve. Precise amount of fuel can only be measured by use of calibrated drip sticks during pre-flight checks.

Flight planning must be based on drip stick measured fuel values!

Caution: After refuelling, the indication is accurate after tanks have levelled. This can take up to 5 minutes. Fuel caps and vents are located on top of the wings.



Fuel valve (9)

Fuel must be used from one tank at a time. For takeoff and landing, the fullest tank must be used. If both tanks are full, the left tank must be used at least for 30 minutes, because the fuel return line feeds into this tank.

The drain valve is located underneath the wing. It must be assured, that no fuel spills on the cockpit windows during fuelling / draining, because fuel can damage lexan windows.

During parking, only one fuel valve must be open and the fuel return valve must be closed. This prevents fuel flow from one tank to the other and overflowing in case of the aircraft not parked in level conditions.

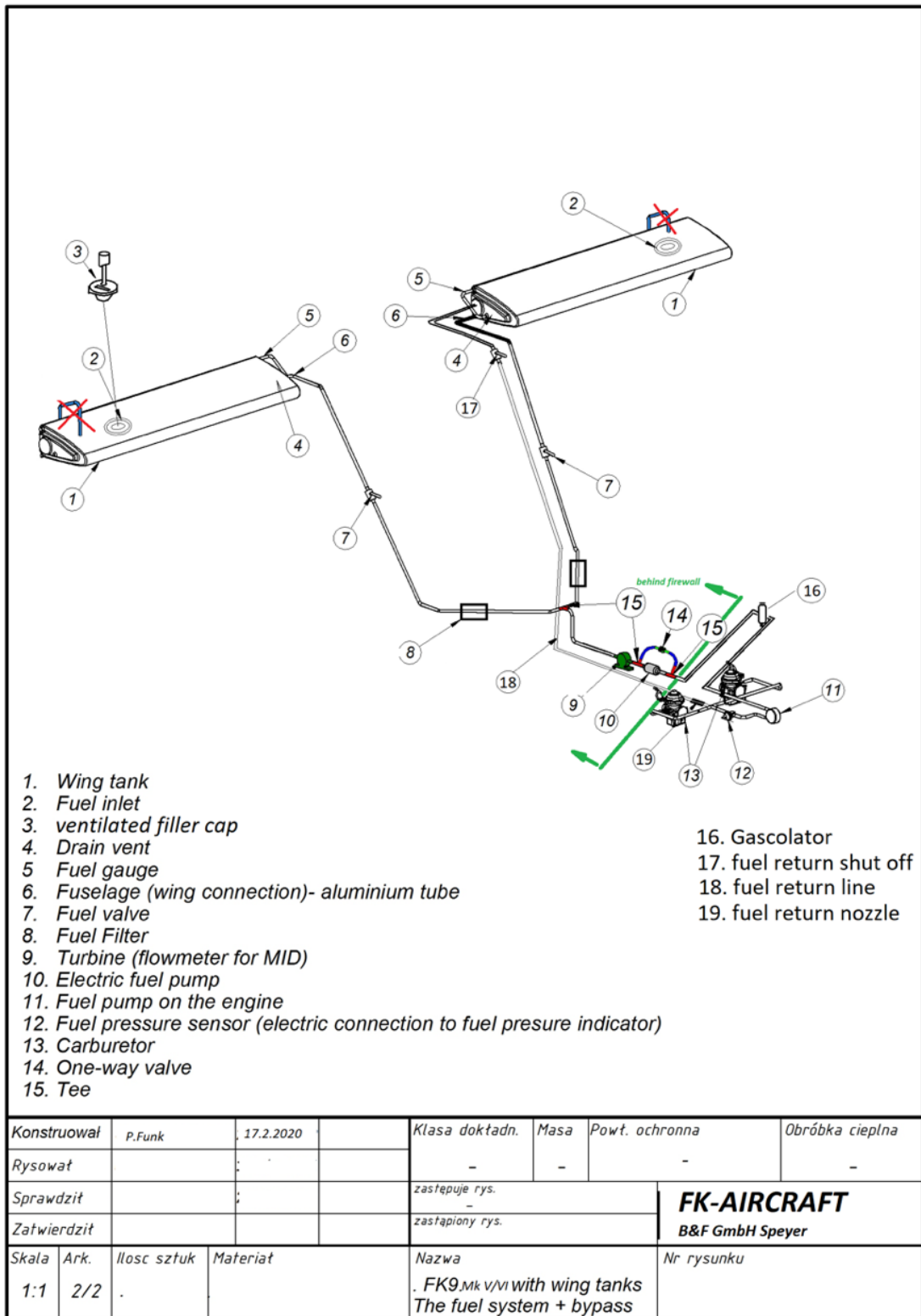

7.13. Brakes

Brakes are controlled by a handle at the center console. Brakes are applied to both main wheels at the same time.

By closing a valve at the center console when pressure has been applied, the hydraulic brake can function as a park brake.

7.14. Heating and Ventilation

The FK 9 is optionally equipped with cabin heating. By pulling the lever at the center console, heated air is allowed to enter the cabin through the front of the pilots feet. The cabin is ventilated by the vents in the doors and the wing roots.

7.15. Electrical System

A 12V engine-driven alternator delivers the required electricity.

If the red alternator control light lights up above 1800 RPM, (or MID / MIP gives a warning) shut off all electrical equipment not required for flight as the battery is not being correctly charged by the alternator and will quickly be discharged.

Panel:

The electrical panel contains most of the switches and electric fuses.

The electrical system is designed for a maximum load of 12 A. Connecting a lot of high - drain components (landing lights etc.) may result in a higher load. This can lead to overheating and / or an electrical smoke / fire condition and must be avoided under all circumstances.

Panels:

Main Panel



additional panel



7.15.1. Wiring Diagram

insert wiring diagram FK 9 Mk VI

8. Handling, Servicing and Maintenance

8.1. General

Every owner of an FK 9 should maintain regular contact with the manufacturer for best support.

8.2. Ground Handling

Aircraft should be parked with the nose facing into the wind and secured by putting chocks in front of the wheels. To tie down the aircraft, attach long straps to the bolts connecting the wing to the strut and also tie down the nose- / tailwheel.

The aircraft should not be parked in wet conditions or exposed to UV radiation for a long period of time.

The windscreen should always be covered during parking to avoid getting dirty.

The FK 9 can be stored in a trailer. For details consult the manufacturer.

8.3. Cleaning

A clean surface is very important for aircraft performance. Therefore the whole aircraft and especially the leading edges of the wings and propeller blades should be kept as clean as possible.

Cleaning is preferably done by using plenty of water, if required a mild soap may be added.

Once a year the painted surface should be treated with a silicon-free polish.

8.4. General Advice

- The vibration dampers on the engine mount should be treated regularly with vaseline to prevent aging.
- Fuel lines, cables and bowden-cables must not be damaged.
- **Note: never turn the propeller for more than 1 turn in opposite direction (ROTAX only)**
- **Airplane maintenance must be performed following the manufacturer's latest maintenance schedule. The actual maintenance schedule can be downloaded from the website www.fk-aircraft.com or www.flugservice-speyer.de**

8.5. Regular Maintenance / Lubrication Schedule

Maintenance is due after certain flight hours or time intervals as applicable. There are some actions which must be performed for the first time after the very first 2 / 10 / 25 flight hours. The regular maintenance intervals are 100 / 200 / 500 flight hours or every year / every 2 / every 5 years.

Engine maintenance must be performed additionally according to the respective engine manual.

Propeller maintenance must be performed additionally according to the respective propeller manual.

8.6. Time between Overhaul (TBO)

- For the main structure: according maintenance schedule FK 9
- propeller: according manufacturer manual
- rescue system: according manufacturer manual
- recommended: engine overhaul according engine manual

insert
maintenance schedule FK 9 Airframe
(DIN A4) here.

8.7. Airplane Servicing

8.7.1. Fuel

During refuelling smoking is prohibited. Connect the airplane to ground. Avoid fuel spill, drain as required. For fuel grades check section Limitations.

Fuel system check / cleaning:

If the fuel tanks are contaminated with dirt (check the inside by using a torch), they must be dismantled (fuselage tanks only) and cleaned. For cleaning, drain the complete system (by using the electrical fuel pump) and dismantle all connections. Clean the tanks by using fuel or spirit / alcohol. Do not use water or solvents.

8.7.2. Oil

Before checking the oil quantity, turn the propeller in normal direction by hand (ignition must be switched OFF) until you hear the oil returning to the tank. Now check the oil level. For oil grades check respective engine manual.

8.7.3. Coolant

Check coolant level preferably with cold engine. For coolant types check respective engine manual.

8.8. Control Surface Angle

	Angle [°]	Tolerance [°]
Elevator		
Up	-24	+1 / -0
Down	+11	+2 / -1
Rudder		
Right	25	+0 / -5
Left	25	+0 / -5
Aileron (Flaps -10°)		
Up	-20	+1 / -1
Down	+17	+2 / -1
Flaps		
Position 0	-10	+1 / -1
Position 1	+5	+1 / -1
Position 2	+20	+1 / -1

8.9. Jacking / Towing / Storage

CAUTION

As a general rule, apply force to aircraft structure only on main structural elements such as frames, ribs or spars.

Jacking:

Use following points for jacking:

1. lower engine mount where connected to the fuselage or engine mount junctions (hanging up)
2. main gear beam where connected to the fuselage
3. nose- / tailwheel where connected to the fuselage

Towing:

For towing (forward only), connect the rope to the main gear.

Storage:

To stow the dismantled wings, use storage tools with a minimum contact area of 150 mm. The leading edge should have no contact to the storage tool in the first 20 mm.

For long distance transport in truck, trailer or container the following dismantling and storage procedure is recommended:

- Dismantle airframe including wings, tailplane.
- Secure controls
- Dismount wheel fairings to avoid damages
- Dismantle propeller
- Disconnect electric circuits, dismantle battery
- De-install shock-sensitive avionics (radio/transponder/glasspanels) and pack in upholstered boxes

Additional for street transport in trailer or truck:

- Drain liquids (oilsystem /coolingsystem / fuelsystem)

Additional for air transport:

- Remove complete engine (considered hazardous goods for air freight!)

Re-launching the aircraft in operation:

Proceed according to check list form "assembly plan / Montageplan"

8.10. Main / Subsidiary Structure

The main structure contains of:

- fuselage structure, tail unit structure, engine mount
- landing gear
- control surfaces
- main plane structure

Repairs at the main structure must only be performed by authorized facilities!

The subsidiary structure contains of:

- front fuselage covers / cowlings (glass fibre composite)
- wheel pants (glass fibre composite)
- spinner
- inside cockpit: covers / consoles / floor

8.11. Materials for minor repairs

Repairs at the subsidiary structure may be performed by the owner, however it is recommended to consult the manufacturer or a certified repair center before commencing the work.

Materials available for fuselage repair:

- Glass fibre layer „Köper“ 160g/sqm
- Epoxy-resin
- 2-component acrylic paint

8.12. Special Repair and Check Procedures

Use common procedures applicable for aircraft build from metal and composite.

8.13. Required Tools

No special tools are required for normal maintenance.

8.14. Weighing

Weighing has to be performed according to the Weighing Form. Weighing intervals according to applicable rules.

8.15. Mounting / Maintenance of the Rescue System

According to the respective manual.

8.16. Assembly of the Aircraft

Assemble the aircraft as follows:

- Check all parts for damage
- Check fuselage and wings for loose or foreign objects
- remove all root tip covers
- Connect the wings to the fuselage (doors must be removed or closed)
- **IMPORTANT** for wing assembly:
unfold the wing with the leading edge facing downwards; turn the wing into its normal position and push it towards the fuselage
- *with wingtanks: connect the wing tank fuel line with the fuselage fuel line; take care that the gauges fit into the gap in the root rip when pushing the wings toward the fuselage; check that the fuel lines are not kinked*
- connect the electric wires; install root rip covers
- close and secure both wing bolts (safety pins)



- Install the strut with its two bolts (the upper one is screwed)



- Cover the gap between wing and fuselage with tape for better aerodynamics
- Secure all bolts
- Install the other wing in the same manner
- The storing device at the aft fuselage can be removed now
- Mount the outer parts of the elevator
- Connect and secure the rods for ailerons
- Connect the pitot tube line
- Install the doors
- Install the strut covers (if available)
- Check the function of all flight controls and flaps

To disassemble the aircraft follow above mentioned steps in reverse order, observe the following steps.

- If required, remove the elevator tips
- install the storing device for the wings at the aft part of the fuselage
- Note: the screws at the main tube of the folding mechanism (overhead the pilots) are the stop for the folding mechanism; they must only be removed it is intended to remove the wings completely from the fuselage
- to fold the wing:
pull the wing outside until the stop, turn it 90° (the leading edge facing to the ground), now fold it and store it into the device

9. Supplements

9.1. General

This chapter contains information concerning additional or differing equipment of the aircraft. Additional manuals and other useful information are indicated.

9.2. Engine Manual

A separate manual for the engine is supplied with every aircraft. Specifications of this manual are part of the airplane manual and must be observed.

9.3. Rescue System

A separate manual for the rescue system is supplied with every aircraft. Specifications of this manual are part of the airplane manual and must be observed.

9.4. Avionics / Special Engine Instruments

A separate manual for avionic components is supplied with every aircraft. Specifications of this manual are part of the airplane manual and must be observed. The equipment is installed according the manual and checked for proper operation.

9.5. Seaplane Floats

If the aircraft is equipped with Seaplane Floats, the maximum take off weight is 640kg / 1410lbs (if permitted by the respective country regulations). Observe Chapter 2 Limitations.

Differences to the basic airplane in normal / abnormal operation are to be determined.

Maintenance of the Floats must be done according the respective manual.

9.6. Sailplane Towing

Caution: sailplane towing is not permitted in Belgium

9.6.1. Technical Data / Limitations

max. towplane gross weight	472,5 kg / 1042 lbs
max. sailplane gross weight*	650 kg / 1433 lbs
takeoff distance to 15 m / 50ft height	550 m / 1804 ft
towing rope type: "200 Polyester / 6mm"	600 daN
max. mass of towing rope (including all parts)	1,5 kg / 3,31 lbs
recommended designed fraction value	150 daN
max. fraction value towing aircraft	200 daN
rope lenght	45-55 m / 147 – 180 ft
min. towing speed	95 km/h / 51 kt

*check for further recommendations in the following chapters
Valid for ISA conditions.

For sailplane towing, a special cowling must be installed.
For further information contact the manufacturer.

9.7. Airplane Flight Training Supplement

The FK 9 is an easy to handle modern airplane.
There are no special training requirements beyond normal pilot's training.